

For over 35 years, Thermo's inline liquid and gas turbine flowmeters have provided highly accurate and repeatable flow measurements. Easy to install and maintain, with minimal disruption to the process, the turbine offers a dependable economical flow metering solution for a wide range of industrial applications.

Model 6500 Model 6600

Inline Turbine Flowmeters for Liquid and Gas



When a customer needs a cost effective, accurate and reliable way of flow metering, Thermo Electron Corporation has the solution. Thermo offers a choice of technologies to suit most customers' requirements, including ultrasonic for larger pipes, and turbine meters for smaller sizes and fiscal management applications. Thermo's inline turbine flowmeters for liquid or gas are widely used in the oil and gas, petrochemical and water treatment sectors and are designed to handle tough industrial applications at a competitive price.

The turbine meter consists of a compact body or spool piece that contains a rotating impeller. The assembly functions very much like a "windmill" in that the rotational speed is directly proportional to the flow rate. The rotor, manufactured from magnetic stainless steel, generates a pulsed output

as the blades rotate through the flux field of a magnet that is contained in the pickup assembly. This feature allows the instrument to function without the need for an exterior power source so that it can be installed in a remote location with a battery powered totalizer or data logger.

The flow measurement data can be read in the field via the local display or can be transmitted to a DCS. Alternatively, a 4-20mA output can go directly into the customer's own process control system.

Turbines are easy to install due to their compact design, which results in minimal downtime for installation and maintenance. Most models are available with standard NPT threads or a variety of ANSI flanges.

Industries

- Oil and Gas
- Petrochemical
- Aerospace
- Water Treatment
- General Process

Features

- Wide range of meter sizes and flange options
- Individually calibrated
- High levels of accuracy and repeatability
- Low pressure drop
- Field repairable
- Cost effective, proven technology

Model 6500 Inline Turbine Flowmeter

The Model 6500 turbine flowmeter is intended for the highly accurate measurement of liquids and gases over a wide range of pipe sizes from 13 mm to 300 mm (0.5 in to 12 in) in diameter. The Model 6500 gives continuous, reliable flow measurement with accuracy levels of better than 0.5% for liquid and 1% for gas. Each instrument is factory calibrated and can be subject to third party calibration if required for an additional fee.

Model 6600 Custody Transfer Liquid Inline Turbine Flowmeter

The Model 6600 custody transfer turbine flowmeter is designed to provide high accuracy liquid flow measurement under the exacting conditions encountered in the refining and petrochemical industry. Capable of achieving accuracy of $\pm 0.15\%$ or better over a specified flow range, it is specifically intended for use in fiscal or custody transfer applications. The Model 6600's unique design provides improved viscosity compensation and low pressure drop. Two pickups are included as standard for dual pulse integrity and superior resolution.

Inline Turbine Flowmeter Physical Dimensions

| | Nominal Bore Size | | Flanged meters end to end | | Threaded meters end to end | |
|------------|-------------------|--------|---------------------------|--------|----------------------------|--------|
| | mm | inches | mm | inches | mm | inches |
| C | 13 | 0.5 | 127 | 5 | 64 | 2.5 |
| D/E | 16 | 0.625 | 127 | 5 | 64 | 2.5 |
| F | 19 | 0.75 | 140 | 5.5 | 83 | 3.25 |
| G | 25 | 1 | 152 | 6 | 89 | 3.5 |
| H | 38 | 1.5 | 178 | 7 | 114 | 4.5 |
| J | 51 | 2 | 197 | 7.75 | 133 | 5.25 |
| K | 76 | 3 | 254 | 10 | | |
| L* | 102 | 4 | 356 | 14 | | |
| M* | 152 | 6 | 368 | 14.5 | | |
| N* | 203 | 8 | 457 | 18 | | |
| P* | 254 | 10 | 457 | 18 | | |
| R* | 304 | 12 | 457 | 18 | | |

*Dimensions apply to both Model 6500 and Model 6600 Inline Turbine Flowmeters

Flanged Flowmeter Dimensions

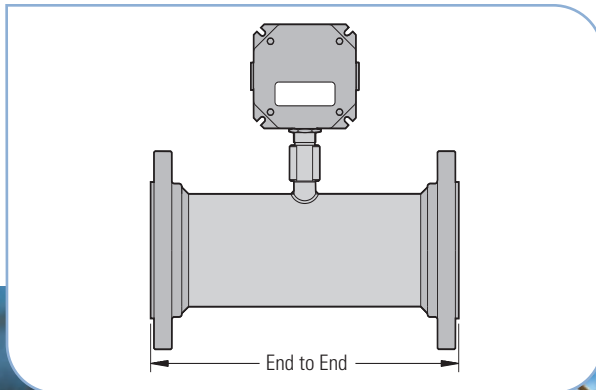

Threaded Flowmeter Dimensions

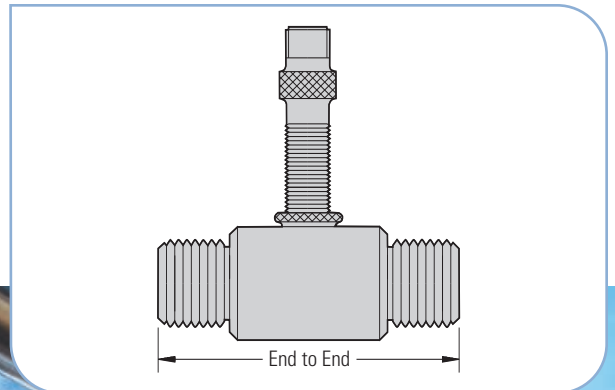



Model 6500 Inline Turbine Flowmeter Ordering Information

MODEL NUMBER

65: Model 6500 Inline Turbine Flowmeter

A. FLUID TYPE

- G:** Gas
- L:** Liquid (Standard Liquid Applications)

B. FLOW RANGE/NOMINAL BORE/THREAD

| | FLOW RANGE (Liquid) | | FLOW RANGE (Gas) | | NOMINAL BORE | | THREAD NPT |
|-----------|--|------------|------------------|--------------------|--------------|-------|---------------|
| | USGPM | l/m | acfm | am ³ /h | mm | inch | |
| C: | 0.5-5 | 1.8-18 | N/A | N/A | 13 | 0.5 | 0.5 |
| D: | 1-10 | 3.6-36 | 0.5-3.75 | 0.88-6.6 | 16 | 0.625 | 0.75 |
| E: | 1.8-18 | 7-70 | 1-7.5 | 1.6-12 | 16 | 0.625 | 0.75 |
| F: | 3.6-36 | 14-140 | 2-15 | 3.2-24 | 18 | 0.75 | 0.75 |
| G: | 7.5-75 | 28-280 | 5-30 | 6.4-48 | 25 | 1 | 1 |
| H: | 15-150 | 56-560 | 6-60 | 10-100 | 38 | 1.5 | 1.5 |
| J: | 30-300 | 112-1120 | 12-120 | 20-200 | 51 | 2 | 2 |
| K: | 60-600 | 225-2250 | 24-240 | 40-400 | 76 | 3 | Flanged only |
| L: | 120-1200 | 450-4500 | 48-480 | 80-800 | 102 | 4 | Flanged only |
| M: | 240-2400 | 900-9000 | 100-1000 | 160-1600 | 152 | 6 | Flanged only |
| N: | 480-4800 | 1800-18000 | 200-2000 | 320-3200 | 203 | 8 | Flanged only |
| P: | 840-8400 | 3200-32000 | 300-3000 | 500-5000 | 254 | 10 | Flanged only |
| R: | 1200-12000 | 4500-45000 | 450-4500 | 800-8000 | 304 | 12 | Flanged only |
| X: | Special — Consult Thermo applications department | | | | | | |

C. BODY MATERIAL

1: 316 stainless steel

D. TEMPERATURE RANGE

- T1:** -20°C to +150°C (0°F to +300°F) — must be used for intrinsically safe operation
- T3:** -200°C to +230°C (-300°F to +450°F) — safe area use only

E. PROCESS CONNECTION

- S1:** Male NPT
- S2:** Male BSP
- 01:** ANSI Class 150 lb raised face, A105 carbon steel, slip on
- 02:** ANSI Class 300 lb raised face, A105 carbon steel, slip on
- 03:** ANSI Class 600 lb raised face, A105 carbon steel, slip on
- 05:** ANSI Class 150 lb raised face, stainless steel, slip on
- 06:** ANSI Class 300 lb raised face, stainless steel, slip on
- 07:** ANSI Class 600 lb raised face, stainless steel, slip on
- XX:** Special — consult Thermo applications department

F. TERMINATION

- 01:** 1-in NPT for ex-proof enclosure or local indicator
- 02:** M25 thread for safe area or I.S.
- 03:** M25 thread suitable for flameproof enclosure
- 04:** 0.75-in NPT for meters smaller than 0.75 in

G. CERTIFICATION

- S:** Non-hazardous/safe area operation
- I:** ATEX Intrinsically safe EEx ia IIB T5
- D:** ATEX Flameproof EEx d IIB T5
- 7:** UL or CSA Class 1, Div 1, Groups B,C,D

H.

Refer to Interface Electronics

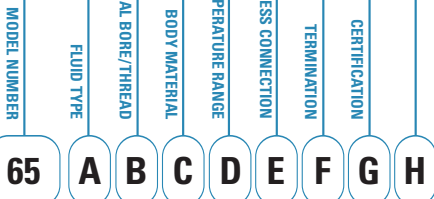

NOTE: Consult Thermo for details of maintenance contracts and additional services including installation, commissioning, re-calibration, service, or repair.



Model 6600 Custody Transfer Liquid Inline Turbine Flowmeter Ordering Information

MODEL NUMBER

66: Model 6600 Inline Turbine Flowmeter

A. FLUID TYPE

L: Liquid (Standard Liquid Applications)

B. FLOW RANGE/NOMINAL BORE/END TO END

| | FLOW RANGE | | NOMINAL BORE | | END TO END | |
|-----------|------------|---------------------|--------------|------|------------|------|
| | GPM | (m ³ /h) | mm | inch | mm | inch |
| L: | 120-1200 | 27-270 | 102 | 4 | 356 | 14 |
| M: | 240-2400 | 55-550 | 152 | 6 | 368 | 14.5 |
| N: | 480-4800 | 110-1100 | 203 | 8 | 457 | 18 |
| P: | 840-8400 | 190-1900 | 254 | 10 | 457 | 18 |
| R: | 1200-12000 | 270-2700 | 304 | 12 | 457 | 18 |

C. BODY MATERIAL

1: 316 stainless steel

D. TEMPERATURE RANGE

T1: -20°C to +150°C (0°F to +300°F)

E. PROCESS CONNECTION

- 01:** ANSI Class 150 lb raised face, A105 carbon steel, slip on
- 02:** ANSI Class 300 lb raised face, A105 carbon steel, slip on
- 03:** ANSI Class 600 lb raised face, A105 carbon steel, slip on
- 05:** ANSI Class 150 lb raised face, stainless steel, slip on
- 06:** ANSI Class 300 lb raised face, stainless steel, slip on
- 07:** ANSI Class 600 lb raised face, stainless steel, slip on
- XX:** Special — consult Thermo applications department

F. TERMINATION

- 01:** 1-in NPT for ex-proof enclosure or local indicator
- 02:** M25 thread for safe area or I.S.
- 03:** M25 thread suitable for flameproof enclosure

G. CERTIFICATION

- S:** Non-hazardous/safe area operation
- I:** ATEX Intrinsically safe EEx ia IIB T5
- D:** ATEX Flameproof EEx d IIB T5
- 7:** UL or CSA Class 1, Div 1, Groups B,C,D

H.

Refer to Interface Electronics

MODEL NUMBER

FLUID TYPE

FLOW RANGE/NOMINAL BORE/END TO END

BODY MATERIAL

TEMPERATURE RANGE

PROCESS CONNECTION

TERMINATION

CERTIFICATION

66

A

B

C

D

E

F

G

H

NOTE: Consult Thermo for details of maintenance contracts and additional services including installation, commissioning, re-calibration, service, or repair.



Interface Electronics for Turbine Flowmeters

INTERFACE ELECTRONICS

- A:** ATEX Flameproof enclosure with terminal block
- B:** ATEX Flameproof enclosure with 4-20 mA analog amplifier
- C:** ATEX Flameproof enclosure with 4-20 mA current modulated pulse
- D:** ATEX Enclosure with terminal block for I.S. service (must be used with I.S. pick-up)
- E:** ATEX Enclosure with 4-20 mA current modulated pulse amplifier for I.S. service (must be used with I.S. pick-up)
- F:** Explosion-proof enclosure with terminal block (CSA)
- G:** Explosion-proof enclosure with 4-20 mA analog amplifier (CSA)
- H:** Explosion-proof enclosure with 5 volt square wave amplifier (CSA)
- I:** Local display with Rate/Total indicator (battery powered)
- J:** Local display with Rate/Total indicator with 4-20 mA output (loop powered)
- K:** Local display with Rate/Total indicator with 4-20 mA output + alarm (DC powered)

NOTES:

1. Items I, J & K are certified Intrinsically safe to European & U.S. standards
Europe: ATEX EEX ia IIB T3 (Group II 2G)
U.S.A.: CSA I.S. for Class 1 Groups C & D
Select certification option (I) when specifying local display
2. All amplifiers require 24 VDC power source
3. Items F, G & H comply with U.S. (NEMA 7) requirements

We can repair or replace turbine products manufactured by the following companies

- Electronic Flow Meters (EFM)
- Automatic Oil Tools (AOT)
- Flow Automation
- Hydril PTD
- Onix Measurement
- Tokheim Automation
- GH Flow Automation



Model 6500 — Inline Turbine Flowmeter for Liquid and Gas

| Specification | |
|----------------------------------|---|
| Functional Specifications | |
| Accuracy | Liquids: $\pm 0.25\%$ of reading for 3-in meters and above $\pm 0.5\%$ of reading for 2-in meters or below Gases: $\pm 1\%$ of reading |
| Repeatability | 0.05% |
| Pressure Drop | Liquids: Typically 300 mbar (4 psi) at normal maximum flow rate in water Gases: Typically less than 0.4 in water gauge at 100% flow rate dependent on gas density |
| Maximum Pressure | As flange rating; Threaded meters: 250 barG (3500 psiG) |
| Physical Specifications | |
| Body Material | 316 stainless steel |
| Flange Material | Forged carbon steel or stainless steel |
| Shaft and Bearing Material | Shafts: Tungsten carbide Sleeve bearings: Durable alloy Ball bearing: Stainless steel ANSI 440C |
| Installation | Install in pipeline with at least 10 pipe diameters of straight length upstream and 5 diameters downstream of flowmeter. For greater accuracy, use upstream flow conditioner. |
| Outputs | |
| Standard Pickup | 30mV at 10% of the flow range |

Model 6600 — Inline Turbine Flowmeter for Liquid and Gas

| Specification | |
|----------------------------------|---|
| Functional Specifications | |
| Accuracy | $\pm 0.15\%$ of reading over a specified range |
| Repeatability | $\pm 0.02\%$ of reading |
| Pressure Drop | Typically 300 mbar (4 psi) at normal maximum flow rate in water |
| Maximum Pressure | As flange rating |
| Physical Specifications | |
| Body Material | 316 stainless steel |
| Flanges Material | A105 carbon steel or stainless steel |
| Bearing Material | Tungsten carbide pinions and sleeves |
| Outputs | |
| Standard | 30 mV at 10% of the flow range |
| Installation | Per API guidelines |

©2006 Thermo Electron Corporation. All rights reserved. Results may vary under different operating conditions. Specifications, terms and pricing are subject to change. Not all products are available in all countries. Please consult your local sales representative for details. Literature code PI.2034.0206

| | |
|---------------------------------------|-------------------------|
| Room 1010-1019 | +86 (10) 5850-3588 |
| Ping'an Mansion No. 23 Jinrong Street | +86 (10) 6621-0847 fax |
| Xicheng Dist., Beijing 100032 CHINA | |
| 415 City Point, 193 Dhole, Patil Road | +91 (20) 5601 1245 |
| Pune 411001 INDIA | +91 (20) 2612 5739 fax |
| Ion Path, Road Three, Winsford | +44 (0) 1606 548700 |
| Cheshire CW7 3GA UK | +44 (0) 1606 548711 fax |
| 1410 Gillingham Lane | +1 (800) 437-7979 |
| Sugar Land, TX 77478 USA | +1 (713) 272-0404 |
| | +1 (713) 272-4573 fax |

Process Instruments

www.thermo.com/process
sales.process@thermo.com